

Ideas by Blum

For a better quality of living
in every home



 **blum**

Inspirations

www.blum-inspirations.com

Welcome to Blum Inspirations

Blum Inspirations is a growing source of inspiration for everyone who is enthusiastic about creative furniture solutions, be it professionally, personally or both. We provide ideas and tips and show you how familiar solutions can be interpreted in a new way.

Practical experiences, trends and innovations pave the way for new solutions

It's very important to us at Blum to understand our customers' needs and requirements and share insights and application ideas with our partners. This exchange is our driver in the development of new products and services.



Contents

- 04 Blum requirements research
- 06 Beautiful and practical
- 10 Ergonomics
- 14 Storage space
- 20 Motion
- 22 Design
- 24 Benefit together

Blum requirements research

For many years now, we have been travelling the world as part of our requirements research to observe kitchen and furniture users as they go about their day-to-day lives. We analyse storage items, document processes and uncover unique requirements in different countries. The resulting findings form the basis for developing high-quality fittings that can provide enjoyment and satisfaction for the lifetime of the furniture.





The AgeExplorer®

A keen eye for observation is important when designing functional fittings for ergonomic furniture.

The AgeExplorer® simulates movement limitations and is one of our most important tools in addition to monitoring global trends in furniture usage. The results of our studies are incorporated in the development of new products and the optimisation of existing ones.



The two aspects of a piece of furniture

Furniture, especially in the kitchen, must be fit for everyday use. Blum has been researching the needs and requirements in kitchens for many years. Thanks to this research, Blum is continuously coming up with new ideas to make modern kitchens even more practical.

Every piece of furniture should fulfil two main functions: it should be aesthetically pleasing, i.e. meet the visual expectations of the user, and still be practical. Blum Inspirations brings both aspects of the furniture together.



Furniture that is fit for everyday use is not only beautiful but also practical

The workflows are well-thought-out and simple. Optimal use is made of the furniture through good planning of the storage space. Enhanced ease of use facilitates everyday tasks, and a high level of design freedom allows for individual styles.

Blum helps to enhance every home with innovative fittings, clever cabinet solutions and useful expertise.

Practical solutions for every home

Demands are placed on furniture fittings on a daily basis. Solutions that are fit for the particularly hard-working processes in a kitchen are also suitable for use in other living areas that are used less intensively.



Ergonomics

Everything is easy to access and clearly organised.



Storage space

Make full use of the storage space available.



Motion

It's easy to open and close furniture.



Design

Turn your creative ideas into reality.

Ergonomics

Identify routines in everyday life

Convenience is vitally important to ergonomic furniture use. We need to know why we require a piece of furniture and be familiar with the processes and activities involving this furniture.

There are a number of activities that vary depending on influences such as country and culture in addition to individual habits.

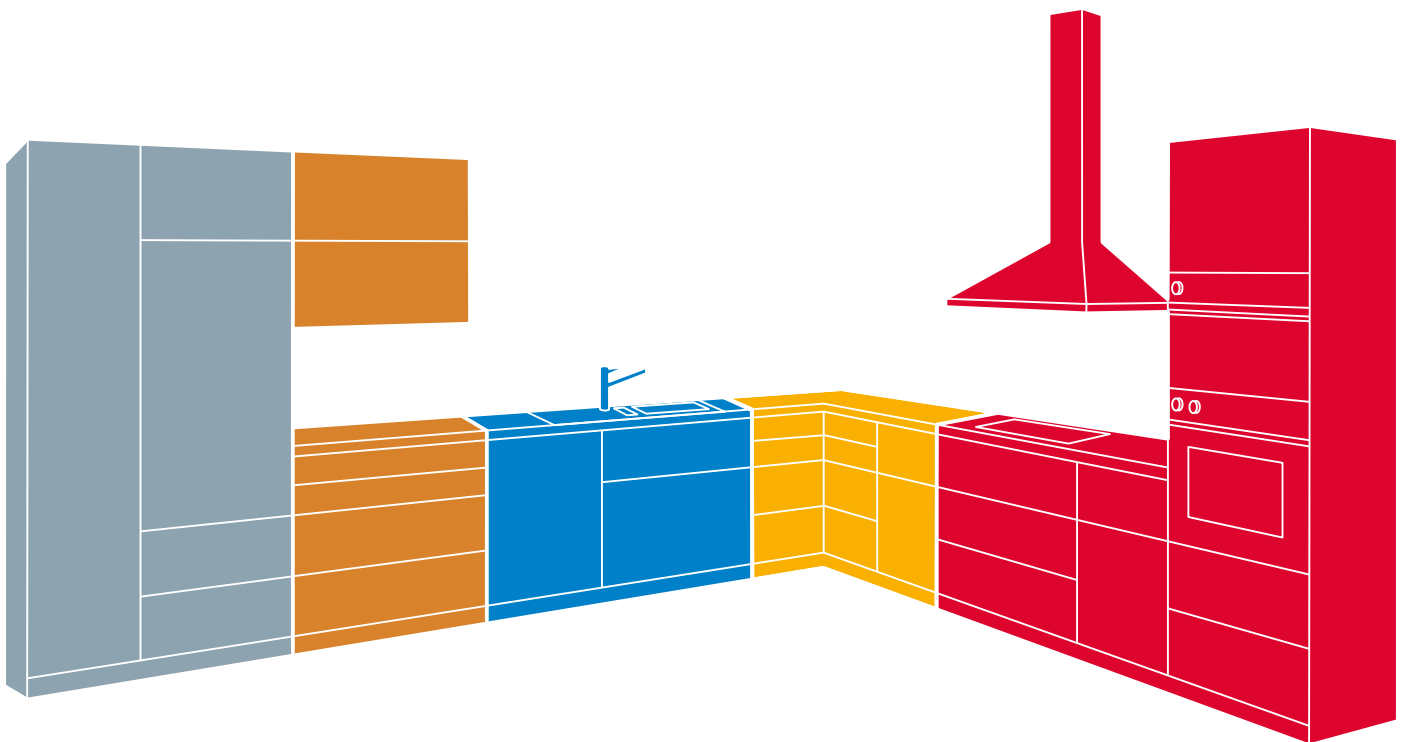

Consumables

Easy access is especially important in the food storage area.



Non-consumables

Cutlery, dishes and glasses are located here. It's useful if this is close to the sink and dishwasher.



Cleaning

Cleaning utensils are stored in the immediate vicinity of the sink and dishwasher.



Preparation

Everything needed to prepare dishes is stored directly below the worksurface between the cooking and cleaning zone.



Cooking

There is storage space next to the hob for pots, pans and cooking utensils.

Define areas of activity and arrange them accordingly

The areas of activity in a kitchen are very easy to define. If you take into account the connections when positioning the furniture, this simplifies daily routines.



Identify and combine areas of activity

There are everyday examples to illustrate simple workflows for every living area. Furniture and spaces often have more than one purpose and areas of activity merge with each other. This should be taken into account right from the planning stage.



Ergonomics

Optimise access

If you want workflows to be simple, all items must be easily accessible. Give yourself easy access. The right cabinet equipment helps here, we always recommend pull-outs in the

base cabinets, as they offer considerable ergonomic benefits compared to doors. In addition, the appropriate inner dividing system provides clear visibility of all contents.

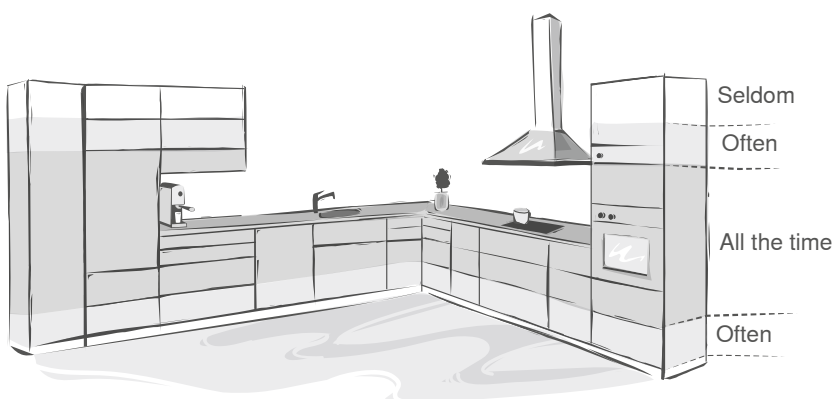

Ergonomic levels

Items that are used often should be easily accessible. Items that are rarely needed are located at the top or bottom of the cabinet, depending on their weight.



Pull-outs instead of doors

All contents can be seen at a glance with pull-outs; access is significantly easier, and you no longer need to bend down and dig things out from the back of a cabinet.

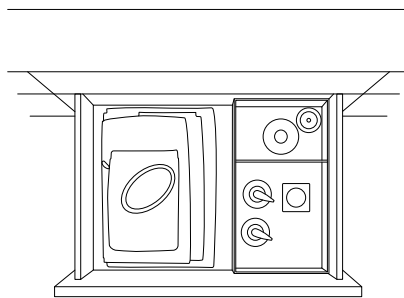
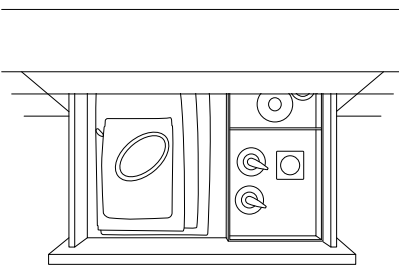

Full extensions

Drawers can be fully extended to give users easy access to all items – even those right at the back. For narrow furniture in particular, it's important to utilise the entire depth.

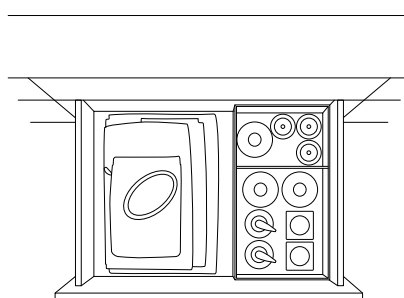
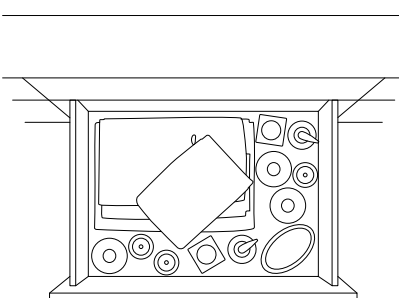

Inner dividing systems

Flexible inner dividing systems organise interiors and provide clear visibility of contents. There is a suitable option for every one of our box systems.



Storage space

Allow for individual requirements

Practical interior fittings feature plenty of storage space. The storage space requirement varies depending on the household size, habits or lifestyle of the furniture users. To ensure that furniture can remain fully functional for a long time, future requirements should be taken into account at the initial planning stage.



Adjust furniture dimensions

Customised furniture helps to make optimal use of the available space. Depending on the requirements, cabinets can vary in terms of height, depth or width to create additional space.

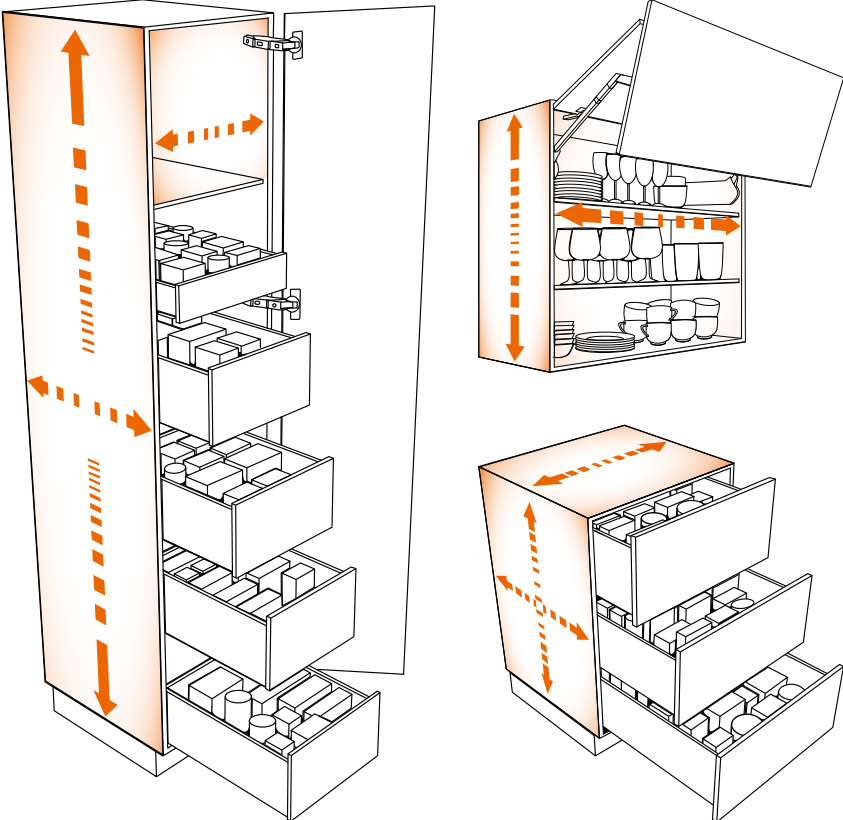



Storage space

Adjust drawer dimensions

One of our most important goals in furniture design is to make the most of the available space. By using deeper furniture with high and closed pull-outs, as well as some thoughtful planning,

every inch of space is used wisely without changing the size of the room.

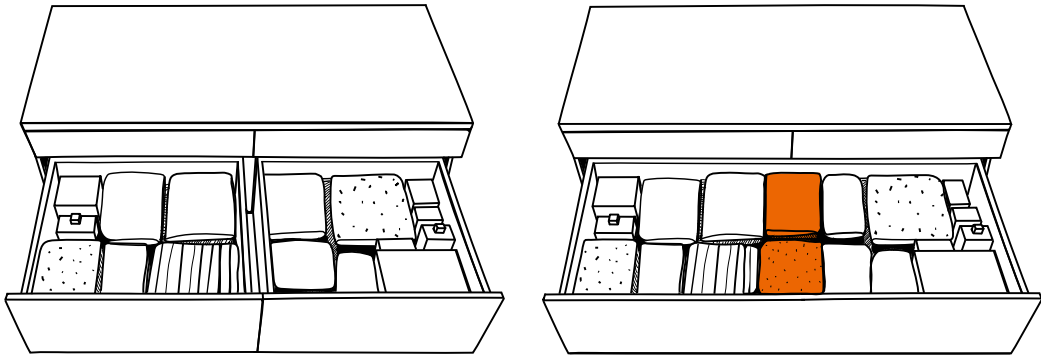

Two in one

The smaller the room, the wider the drawers should be. By using a wide pull-out instead of two narrow ones, you can create up to 15% more storage space.

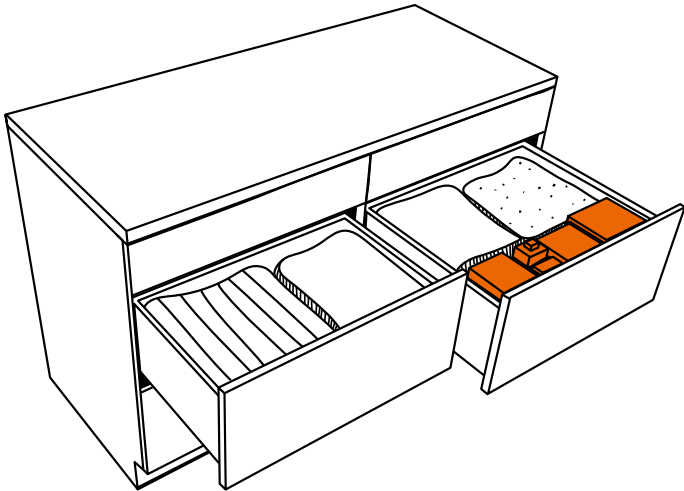

Think deep

Pull-out systems with greater depth give you up to 30% more storage space. The entire depth of the furniture is used as storage space. In some areas, extra-deep cabinets can even be used.

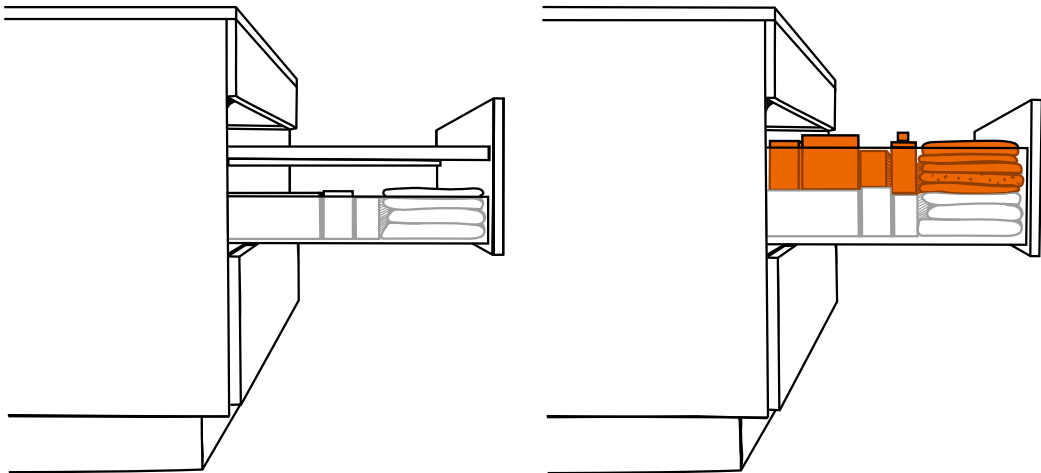

Open vs. closed

By using pull-outs with closed sides and a high back panel, up to 55% more storage space can be created, as contents can be stacked, and items are prevented from falling down the back of the cabinet.

Create new storage space

Innovative cabinet solutions mean that not an inch is wasted. New ideas create storage space in places you would never have imagined. Replace the false drawer-front of a sink unit with a pull-out for cleaning utensils.





The SPACE TOWER larder unit can be chosen to suit the width of the storage space. The individual inner pull-outs are easily accessible from all sides.



The SPACE STEP plinth solution provides a step for easy access to high cabinets and hidden storage space all in one.



The SPACE TWIN fills gaps in the kitchen, which would otherwise be a filler, with practical storage options in the smallest space.



The drawers in the SPACE CORNER cabinet are suitable for cutlery and knives; pull-outs also offer plenty of space for pots and pans.

Motion

Inspiring technology

Easy opening, a feather-light glide and soft close, all thanks to ultra-modern technology, these features all undergo intensive quality tests before being put into practice.

All in all, kitchen drawers, pull-outs, doors and wall cabinet fronts are opened and closed more than 80 times a day. But even if used less frequently in other living areas, durable and reliable motion is essential.





BLUMOTION soft-close mechanism

The BLUMOTION soft-close mechanism has almost become a standard feature and allows drawers, doors and wall cabinet fronts to close softly and effortlessly.



Electric opening with SERVO-DRIVE

The SERVO-DRIVE electrical motion support system is available for lift systems and pull-outs. Furniture opens at a single touch and lift systems close at the push of a button.

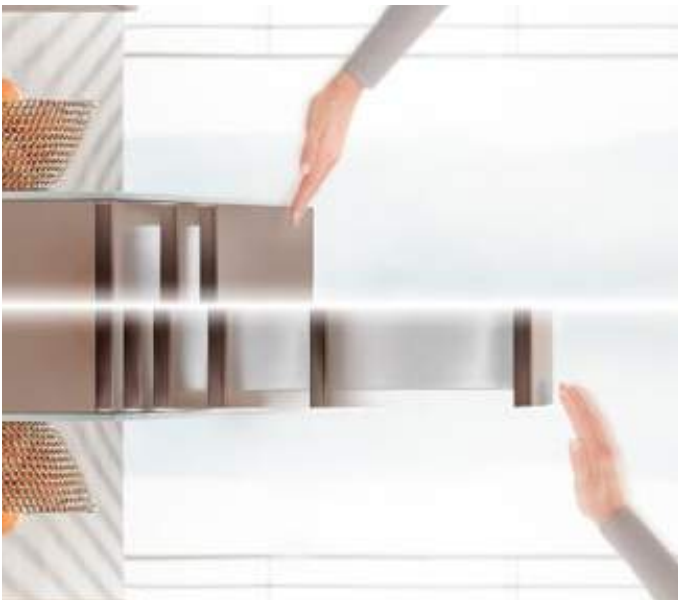

Inspiring combination with TIP-ON BLUMOTION

TIP-ON BLUMOTION for pull-outs combines the advantages of the TIP-ON mechanical opening support system with the tried and tested BLUMOTION soft-close system.



Mechanical opening with TIP-ON

TIP-ON gives you one-touch opening for handle-less fronts. To close, simply press the drawers or doors shut.

Design

Design comes from inspiration

Providing inspiration means giving ideas and sharing knowledge. Blum Inspirations shows how our products support bespoke design, for a better quality of living throughout the home. Create visual impact in different design trends and furniture creations with Blum products.

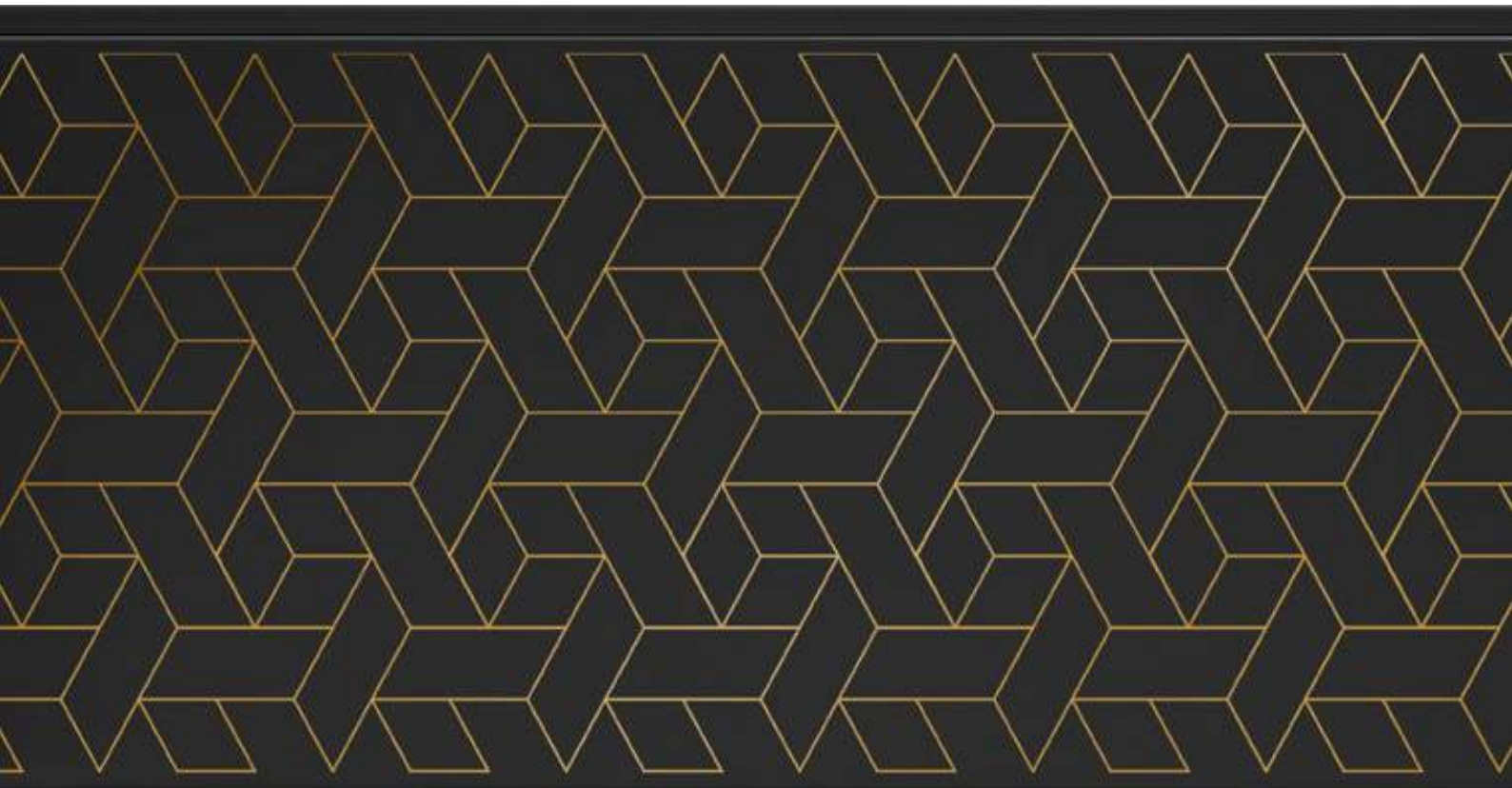

Individuality

We fulfil customer requirements – you can present furniture with the brand or your own name. Blum creates the space and freedom for you to stand out even more as a customer. Logo prints and flexible design solutions allow highly individualised design to be carried through to interiors.



Dark surfaces

The trend towards creating visual impact in furniture continues – with Blum products, this can be achieved even where it can only be seen at a second glance: in the interior of the furniture. Dark fittings for a harmonious balance or a deliberate contrast.



Handle-less furniture

A design trend that has been around for a long time, where the functionality of the furniture is in the spotlight. Motion technologies for lift systems, doors and pull-outs open up many variations for handle-less furniture.



Thin fronts

Furniture design with special fronts is very on-trend. Materials such as natural stone, ceramic or HPL open up new design options. The innovative EXPANDO T solution allows you to implement fronts with a thickness of just 8 mm and is ideal for both very hard and very soft materials – for limitless designs.



Wide fronts

The use of new materials and different front thicknesses places new demands on furniture fittings. The trend towards closing off large living areas and furniture calls for new solutions. We ensure that Blum fittings deliver high stability and smooth running characteristics, regardless of the size and weight of the fronts.



Benefits and opportunities

Benefit from Blum Inspirations together

We would like to share useful findings and inspire you with our practical cabinet applications. Our innovative products and practical cabinet solutions support you with furniture planning and make everyday life easier.



Showrooms

Showrooms come to life when using our innovative ideas. Potential buyers can experience the functionality and added value of good fittings.

Product range

Practical cabinet solutions and interior fittings provide a variety of ideas for the product range. Kitchen planners can meet their customers' individual needs.

Sales

Talking about the added value and benefits of a practical kitchen gives potential kitchen buyers the confidence to go through with their decision to invest in a new kitchen.

Marketing communication

We have a wide range of brochures, information materials, videos, photos and drawings to support kitchen manufacturers, planners, distributors and cabinet makers.



moving ideas

We believe that ideas can move the world. We offer innovative fittings, inspiring furniture concepts and appropriate services so that you can turn your creative ideas into reality. We are driven by your needs, international trends and our shared vision of a better quality of living. Let us work together to create moving ideas.



Quality of living

We would like you to enjoy greater convenience and functionality when using furniture.



Product range

Everything from a single source: our wide range of products allows you to keep up with today's and tomorrow's trends.



Inspiration

We monitor global trends and strive to create the solutions of tomorrow. We like to share our insights with you.



Innovation

We stay in motion. Curiosity and pioneering spirit drive us to develop new products and services for you.



Services

We support your daily operations with customised services tailored to your processes.



Quality

We continuously strive to improve our products, services and ourselves.



Trust

We take responsibility for partnerships, our employees, society and the environment.

Julius Blum started our journey in 1952 with horseshoe studs. Today we supply innovative fittings to customers in over 120 countries.

Julius Blum GmbH
Furniture Fittings Mfg.
6973 Höchst, Austria
Tel.: +43 5578 705-0
Fax: +43 5578 705-44
E-mail: info@blum.com
www.blum.com

Our sites in Austria, Poland and China are certified to the international standards mentioned below.
Our site in the USA is certified to ISO 9001.
Our site in Brazil is certified to ISO 9001, ISO 14001 and ISO 45001.



ISO 9001
Certified Quality
System



ISO 14001
Certified Environmental
System



ISO 50001
Certified Energy
System

 **blum**®



Look for our
FSC™-certified
products

All content is copyrighted by Blum.
Subject to technical modifications and changes to the range without notice.
IDNR: 441.521.6 · EP-531/1 EN-AL/05.23