

## Connection of the hold-down devices to the newly certified MINIPRESS P

Connection diagram of the existing MINIPRESS P without hold-down device:

### Ausführung ohne Niederhalter

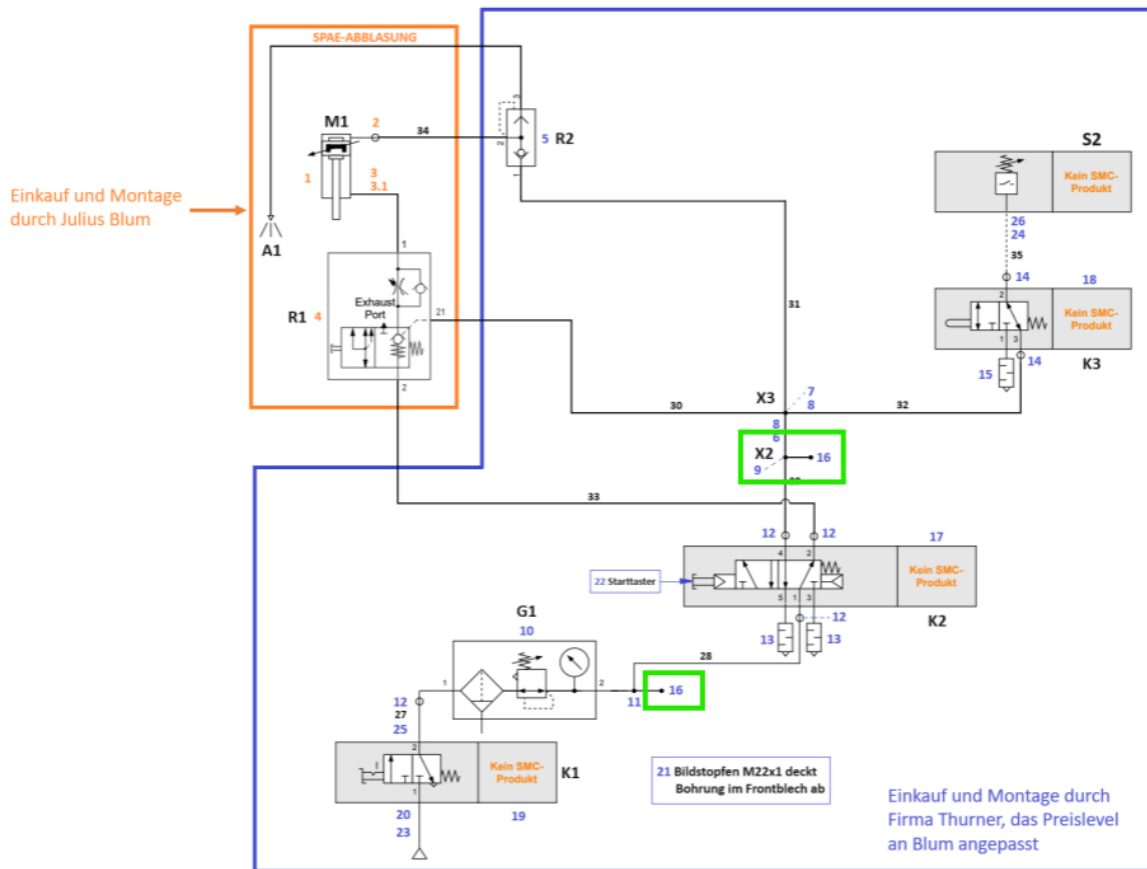

The two connections 16 are equipped with blind plugs, for connecting to the switching valve.

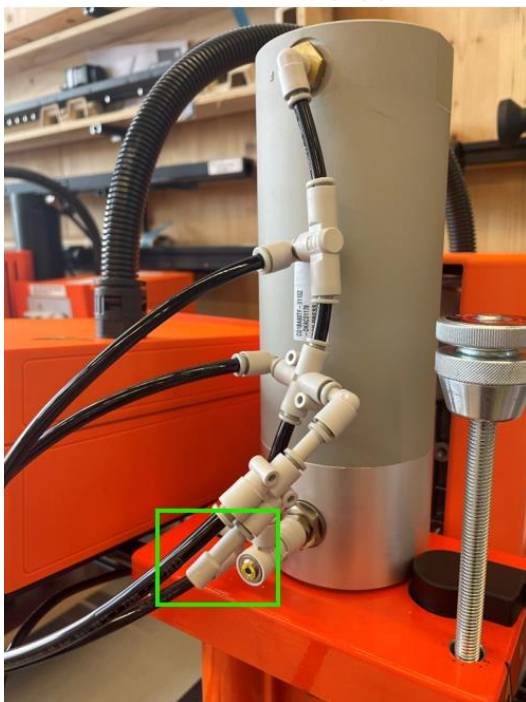

Connection X2



Connection to the pressure regulator

Connection diagram of the original hose-connected MINIPRESS P, with hold-down device.

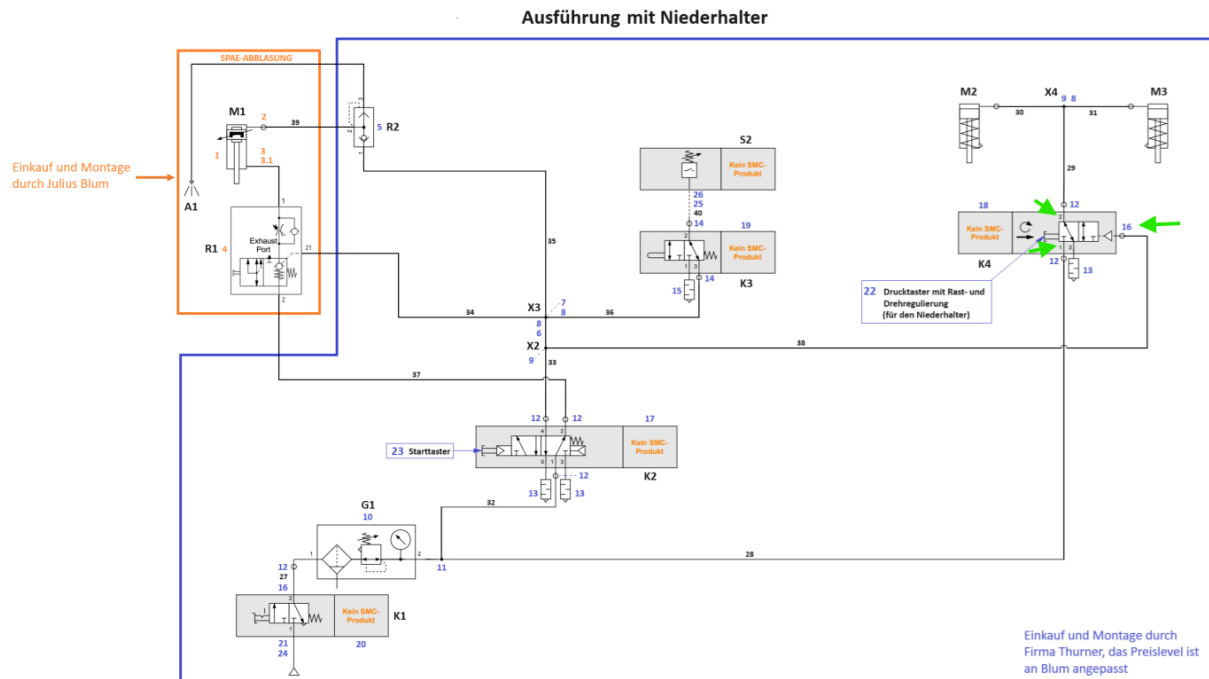

There are numbers on the switching valve, meaning 1 = this is where the hose from the supply line (compressed air regulator) comes in.

Number 2, this is where the hoses go to the hold-down devices.

The 3 goes to the connection on cylinder X2.

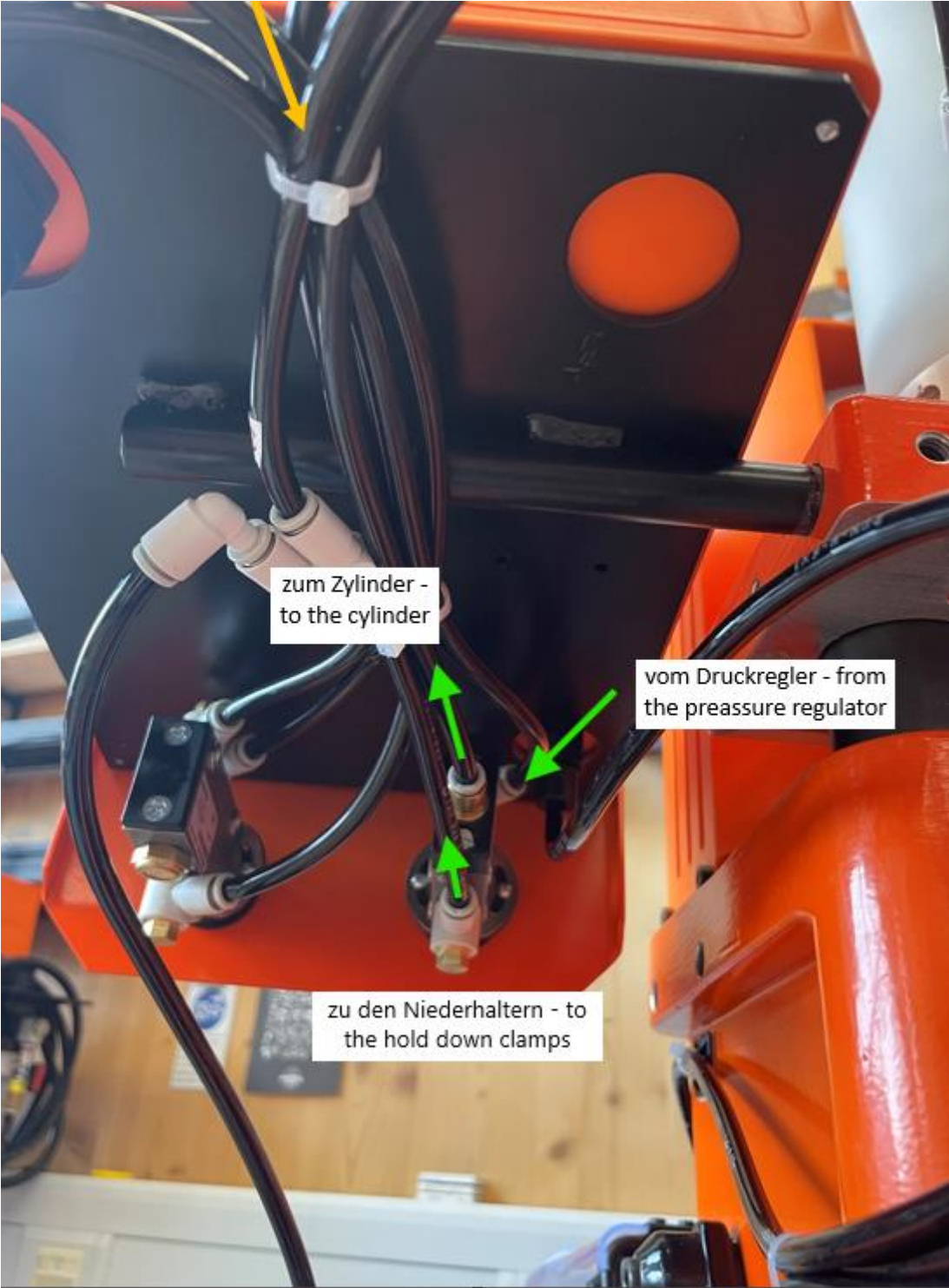

zum Zylinder -  
to the cylinder

vom Druckregler - from  
the pressure regulator

zu den Niederhaltern - to  
the hold down clamps

Then fasten the hoses again with cable ties.

Kabelbinder

